

Data sheet

HC49/U

Through Hole Quartz Crystal (11.0 x 4.7 x 13.5 mm)

FEATURES

- Wide frequency range
- High reliability by means of resistance weld hermetic seal
- Excellent aging characteristics
- High precision availability
- Applications: Telecommunication equipment, PC boards...

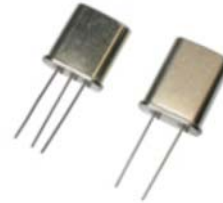

Parameter	min.	typ.	max.	Unit	Condition
Frequency range	1.8432		176.0	MHz	
	Fundamental	1.8432	48.0	MHz	For higher frequencies in 7th overtone please consult FCD-Tech
	3rd overtone	26.0	90.0	MHz	
	5th overtone	80.0	176.0	MHz	
Vibration mode	AT cut, fundamental, 3rd, 5th ovt				
Frequency stability					
Initial tolerance @25°C		±30		ppm	Specify (see options)
vs. operating temperature range		±30		ppm	Specify (see options)
operating temperature range	-10		+60	°C	Specify (see options)
Equivalent Series Resistance (ESR)	See table 1				
Load Capacitance (CL)	Series or 8pF to 32pF (see options)				
Shunt Capacitance (Co)			7.0	pF	
Drive Level			1000	µW	
Aging		±5	±2	ppm	At 25°C, first year
Insulation Resistance	500			MΩ	@ 100Vdc
Enclosure (see drawing) (LxWxH)	HC49/U	11.0 x 4.7 x 13.5		mm	
	HC49/T	11.0 x 4.7 x 11.3		mm	
	HC49/T3	11.0 x 4.7 x 9.5		mm	
Packing	Bulk in bag				

Ordering Code:

Version (H in mm)	Freq. Tolerance @ 25°C	Freq. Stability	Operating Temp. range	Load Capacitance	Mode	Frequency in MHz	ESR if other than STD
HC49/U = 13.5	05 = ± 5ppm	05 = ± 5ppm	D = -10° / +60°C	Please specify CL	F = Fundamental	Specify the	Specify a value
HC49/T = 11.3	10 = ± 10ppm	10 = ± 10ppm	E = 0° / +70°C	in pF or	3 = 3rd ovt	frequency in MHz	in Ω
HC49/T3 = 9.5	15 = ± 15ppm	15 = ± 15ppm	F = -20° / +70°C	S for series	5 = 5th ovt		
	20 = ± 20ppm	20 = ± 20ppm	G = -30° / +75°C				
	25 = ± 25ppm	25 = ± 25ppm	H = -30° / +85°C				
	30 = ± 30ppm	30 = ± 30ppm	K = -40° / +85°C				
	50 = ± 50ppm	50 = ± 50ppm					

Example: HC49/T3-10-10-E-S-3-33.500MHz

3rd lead is an option. Specify as '-3L' (example: HC49/U-20-20-F-30-F-16.000MHz-3L)

Data sheet

HC49/U

Through Hole Quartz Crystal (11.0 x 4.7 x 13.5 mm)

Outline Dimensions:

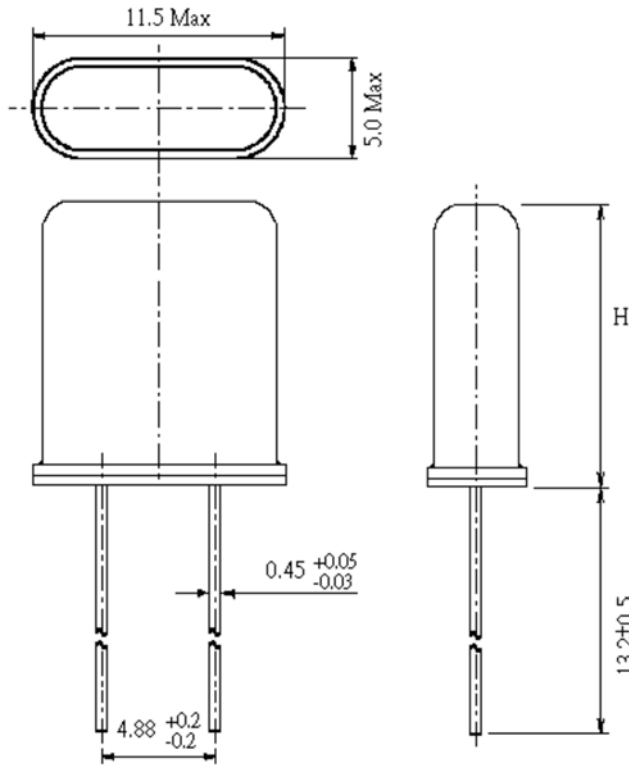

Table 1 : Standard ESR

Frequency	Mode	ESR
1.8432 MHz	Fundamental	500 Ω max.
2.0 ~ 2.9 MHz	Fundamental	350 Ω max.
3.0 ~ 3.1 MHz	Fundamental	200 Ω max.
3.2 ~ 3.9 MHz	Fundamental	150 Ω max.
4.0 ~ 4.4 MHz	Fundamental	100 Ω max.
4,5 ~ 4.9 MHz	Fundamental	80 Ω max.
5.0 ~ 6.9 MHz	Fundamental	50 Ω max.
7.0 ~ 9.9 MHz	Fundamental	35 Ω max.
10.0 ~ 48.0 MHz	Fundamental	25 Ω max.
26.0 ~ 90.0 MHz	3rd ovt	70 Ω max.
80.0 ~ 176.0 MHz	5th ovt	120 Ω max.

Type	Height (max.)
HC49/U	13.5mm
HC49/T	11.3mm
HC49/T3	9.5mm

Environmental conditions

Test	IEC 60068 Part ...	IEC 60679-1 clause ...	Test conditions (IEC)
Sealing tests (if applicable)	2-17	5.6.2	Gross leak: Test Qc, Fine leak: Test Qk
Solderability	2-20	5.6.3	Test Ta Method 1
Resistance to soldering heat	2-58		Test Td ₁ Method 2 Test Td ₂ Method 2
Shock*	2-27	5.6.8	Test Ea, 3 x per axes 100g, 6 ms half-sine pulse
Vibration, sinusoidal*	2-6	5.6.7.1	Test Fc, 30 min per axes, 10 Hz - 55 Hz 0,75mm; 55 Hz - 2 kHz, 10g
Vibration random *	2-64	5.6.7.3	Test Fdb
Endurance tests			
- ageing		5.7.1	30 days @ 85°C, OCXO @25°C
- extended aging		5.7.2	1000h, 2000h, 8000h @85°C

Rev. 2 dated 01-02-2013