

Data sheet

HC49-US SMD

2 pad SMD Crystal (metal welded package)

11.4 x 4.7 x 4.2 mm

FEATURES

- Metal welded package, 2 pad SMD Crystal HC49-US
- High resolution frequency tolerance is obtained
- Frequency range 3.0MHz - 150MHz
- Options for initial tolerance and temperature stability
- Height 2.5mm available



Parameter	min.	typ.	max.	Unit	Condition
Frequency range	3.000		54.000	MHz	Fundamental mode
	36.000		150.000	MHz	3rd overtone mode
Vibration mode	AT cut, fundamental, 3rd overtone				
Frequency stability					
Initial tolerance @25°C		±30		ppm	See options
vs. operating temperature range		±30		ppm	See options
operating temperature range	-10		+60	°C	See options
Equivalent Series Resistance (ESR)	See table 1				
Load Capacitance (CL)	16pF, 18pF, 20pF or specify (see options)				
Shunt Capacitance (Co)			5.0	pF	
Drive Level			300	µW	
Aging			±2	ppm	At 25°C, first year
Insulation Resistance	500			MΩ	@ 100Vdc
Enclosure (see drawing) (LxWxH)	11.4 x 4.7 x 4.2			mm	2 pad type
Soldering Condition	260°C, 10 sec x 2 max.				
Packing	2,000 pcs./reel				

Table 1 : Standard ESR

Frequency	Mode	ESR
3.0 ~ 3.9MHz	Fundamental	150Ω max.
4.0 ~ 4.9MHz	Fundamental	130Ω max.
5.0 ~ 5.9MHz	Fundamental	120Ω max.
6.0 ~ 7.9MHz	Fundamental	100Ω max.

Frequency	Mode	ESR
8.0 ~ 9.9MHz	Fundamental	80Ω max.
10.0 ~ 14.9MHz	Fundamental	60Ω max.
15.0 ~ 54.0MHz	Fundamental	40Ω max.
36.0 ~ 150MHz	3rd overtone	70Ω max.

Ordering Code:

Freq. Tolerance @ 25°C	Freq. Stability	Operating Temp. range	Load Capacitance	Mode	Frequency in MHz	ESR if other than STD
10 = ± 10ppm	10 = ± 10ppm	D = -10 / +60°C	Please specify CL	F = Fundamental	Specify the	Specify a value
15 = ± 15ppm	15 = ± 15ppm	E = 0° / +70°C	in pF or S for series	3 = 3rd overtone	frequency in MHz	in Ω
20 = ± 20ppm	20 = ± 20ppm	F = -20° / +70°C				
25 = ± 25ppm	25 = ± 25ppm	G = -30° / +75°C				
30 = ± 30ppm	30 = ± 30ppm	H = -30° / +85°C				
50 = ± 50ppm	50 = ± 50ppm	K = -40° / +85°C				

Example: HC49-US SMD-30-50-D-S-F-33.300MHz

Data sheet

HC49-US SMD

2 pad SMD Crystal (metal welded package)

Outline Dimensions:

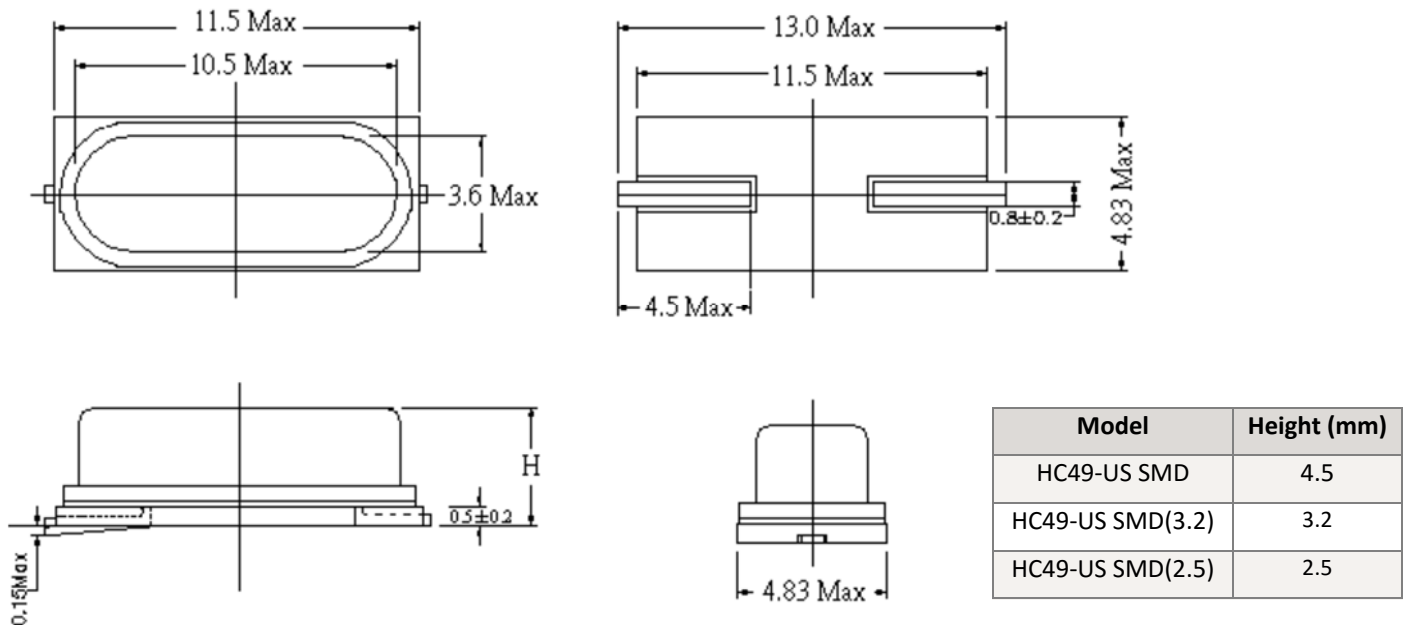

Environmental conditions

Test	IEC 60068 Part ...	IEC 60679-1 clause ...	Test conditions (IEC)
Sealing tests (if applicable)	2-17	5.6.2	Gross leak: Test Qc, Fine leak: Test Qk
Solderability	2-20	5.6.3	Test Ta Method 1
Resistance to soldering heat	2-58		Test Td ₁ Method 2 Test Td ₂ Method 2
Shock*	2-27	5.6.8	Test Ea, 3 x per axes 100g, 6 ms half-sine pulse
Vibration, sinusoidal*	2-6	5.6.7.1	Test Fc, 30 min per axes, 10 Hz - 55 Hz 0,75mm; 55 Hz - 2 kHz, 10g
Vibration random *	2-64	5.6.7.3	Test Fdb
Endurance tests			
- ageing		5.7.1	30 days @ 85°C, OCXO @25°C
- extended aging		5.7.2	1000h, 2000h, 8000h @85°C

Rev. 9 dated 01-02-2014