

## Datasheet

### AXIOM45

### High Stability Eurocase OCXO with Sine Wave Output

Rev. 8

Date: 2014-04-18

#### FEATURES

- Eurocase CO 08 Through Hole package, size 36.1 x 27.2 x 16 mm
- High Stability till +/- 5 ppb over temperature range
- Standard frequencies : 10.000 / 20.000 / 100.000 MHz
- Sine Wave Output

36.1 x 27.2 x 16 mm max.  
CO 08 package

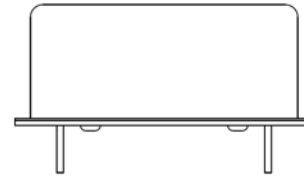

Parameter	min.	typ.	max.	Unit	Condition
Frequency range	5		125	MHz	
Standard frequencies	10.000 / 20.000 / 100.000			MHz	
<b>Frequency stability</b>					
Initial tolerance @+25°C		± 500		ppb	@ V <sub>REF</sub> /2
vs. operating temperature range	Option 2 & 3 See tables 1 & 2				steady state
vs. supply voltage variation (pushing)			± 10	ppb	V <sub>S</sub> ± 5%
vs. load change (pulling)			± 10	ppb	R <sub>L</sub> ± 10%
Long term (aging) per day (after 30 days operation) (Note 2)			± 10 ± 2	ppb ppb	AT-Cut SC-Cut
Long term (aging) 1 <sup>st</sup> year (after 30 days operation) (Note 2)			± 500 ± 200	ppb ppb	AT-Cut SC-Cut
<b>Frequency adjustment range</b>					
Electronic Frequency Control (EFC) range	± 2 ± 0.8		± 5	ppm ppm	AT-Cut SC-Cut
EFC voltage V <sub>C</sub>	0	V <sub>REF</sub> /2	V <sub>REF</sub>	V	
EFC slope (Δf / ΔV <sub>C</sub> )	positive				
EFC input impedance	100			kΩ	
<b>RF output</b>					
Signal waveform	Sine wave				
Load R <sub>L</sub>	50			Ω	± 10%
Output level (Note 3)	+3			dBm	
Harmonics			-25	dBc	
Warm-up time @25°C		3	5	min	Δf <sub>final</sub> /f <sub>0</sub> < ±0.1 ppm
<b>Phase Noise</b>					
Consult FCD-Tech					
Reference voltage V <sub>REF</sub> output (Note 4)		4.0 5.0		V V	Option 1 = "50" Option 1 = "12"
Supply voltage V <sub>S</sub>	4.75 11.4	5.0 12.0	5.25 12.6	V V	Option 1 = "50" Option 1 = "12"
Current consumption (steady state) @ +25°C (Note 5)			250 150	mA mA	Option 1 = "50" Option 1 = "12"
Current consumption (warm-up) (Note 5)			600 350	mA mA	Option 1 = "50" Option 1 = "12"
Enclosure (see drawing) LxWxH (Note 6)	36.1x27.2x16 max.			mm	IEC 60679-3 CO 08
Weight			25	gram	
Packing	Palette				

#### Notes:

1. Terminology and test conditions are according to IEC standard IEC60679-1 and MIL-PRF-55310, unless otherwise stated
2. Lower aging on request
3. Other output level on request
4. Other reference voltages on request
5. May be higher for wide operating temperature range
6. Lower height H available on request

## Datasheet

# AXIOM45

## High Stability Eurocase OCXO with Sine Wave Output

Rev. 8

Date: 2014-04-18

### Absolute Maximum Ratings

Parameter	min.	max.	Unit	Condition
Supply Voltage $V_s$	-0.5	$V_s + 10\%$	V	$V_s$ to GND
Control Voltage $V_c$	-0.5	15	V	$V_c$ to GND
Storage Temperature	-55	+125	°C	

### Frequency stability vs. temperature

Option 2	Stability	Lower Temperature		Upper Temperature	
	[ppb]	Option 3	T [°C]	Option 3	T [°C]
05	±5	0	0	A	+50
10	±10	1	-10	B	+60
25	±25	2	-20	C	+70
50	±50	3	-30	D	+75
100	±100	4	-40	E	+80
200	±200	5	-55	F	+85

Table 1

Table 2

Standard: "1B" = -10 to +60°C

Temperature Range [°C]	Frequency stability [Option 2]					
	05	10	25	50	100	200
0 ~ +50	SC	SC	SC	AT	AT	AT
-10 ~ +60	SC	SC	SC	AT	AT	AT
-20 ~ +70	SC	SC	SC	SC	AT	AT
-30 ~ +70	O	SC	SC	SC	SC	AT
-40 ~ +75	O	O	SC	SC	SC	SC
-40 ~ +85	O	O	SC	SC	SC	SC
-55 ~ +85	-	O	O	SC	SC	SC

Table 3 "Availability" AT, SC = AT-Cut, SC-Cut available, O = available on request, - = not available

### Environmental conditions

Test	IEC 60068 Part ...	IEC 60679-1 clause ...	MIL-STD-202G Method	MIL-STD-810F Method	MIL-PRF-55310D Clause	Test conditions (IEC)
Sealing tests (if applicable)	2-17	5.6.2	112E		3.6.1.2	Gross leak: Test Qc, Fine leak: Test Qk
Solderability	2-20	5.6.3	208H		3.6.52	Test Ta Method 1
Resistance to soldering heat	2-58		210F		3.6.48	Test Td <sub>1</sub> Method 2 Test Td <sub>2</sub> Method 2
Shock*	2-27	5.6.8	213B	516.4	3.6.40	Test Ea, 3 x per axes 100g, 6 ms half-sine pulse
Vibration, sinusoidal*	2-6	5.6.7.1	201A 204D	516.4-4	3.6.38.1 3.6.38.2	Test Fc, 30 min per axes, 10 Hz - 55 Hz 0,75mm; 55 Hz - 2 kHz, 10g
Vibration, random*	2-64	5.6.7.3	214A	514.5	3.6.38.3 3.6.38.4	Test Fdb
Endurance tests			108A			
- ageing		5.7.1			4.8.35	30 days @ 85°C, OCXO @25°C
- extended aging		5.7.2				1000h, 2000h, 8000h @85°C

## Datasheet

### AXIOM45

### High Stability Eurocase OCXO with Sine Wave Output

Rev. 8

Date: 2014-04-18

#### Enclosure drawing:

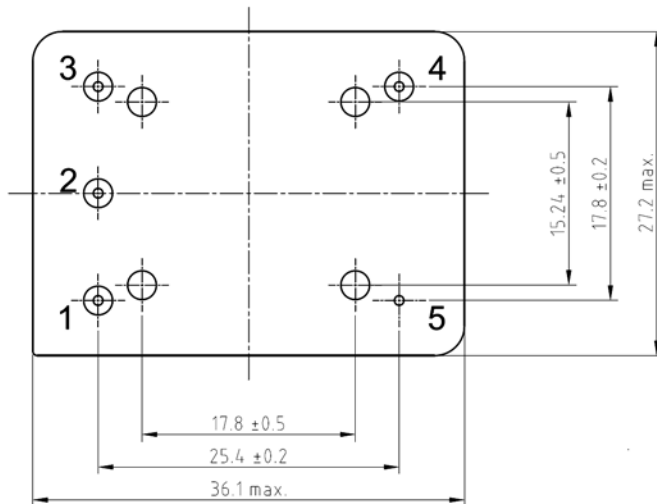

#### Pin connections

Pin #	Symbol	Function
1	V <sub>C</sub>	Control Voltage (EFC)
2	VREF	Reference Voltage
3	V <sub>S</sub>	Supply Voltage
4	RF OUT	RF Output
5	GND	Ground

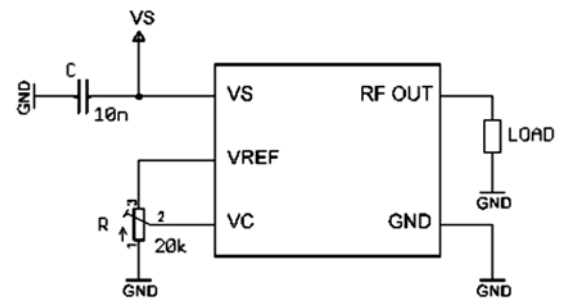
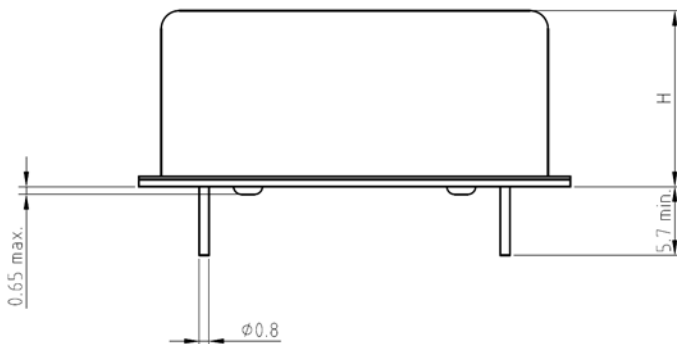

#### Ordering Code

Model	Option 1 [Supply Voltage]	Option 2 [Stability]	Option 3 [Temperature range]	Revision	Frequency [MHz]
AXIOM45	12, 50	Table 1	Table 2	Rev.8	10.000

Example: AXIOM45-12-10-1B\_Rev.1-10.000MHz

#### Handling and Testing:

Parameter	Procedure		Condition
Electrostatic discharge (ESD)			
THD devices	IEC60749-26	HBM	2000V
SMD devices	IEC60749-27	MM	200V
Washable	Yes		
RoHS-Compliant	Yes		