

Data sheet

AXIOM10

High Stability SMD OCXO with HCMOS Output

Rev. 8

Date: 2014-04-18

FEATURES

- SMD package : 25.6 x 22.2 x 12 mm max.
- Standard frequencies available
- Output HCMOS
- Electronic Frequency Control (EFC)

25.6 x 22.2 x 12 mm max.

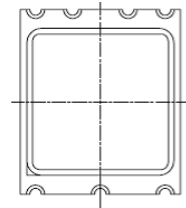

Parameter	min.	typ.	max.	Unit	Condition
Frequency range	10		125	MHz	
Standard frequencies	10.000 / 20.000 / 40.000 / 100.000			MHz	
Frequency stability					
Initial tolerance @ +25°C			± 300	ppb	V _C @ V _{REF} /2
vs. operating temperature range (steady state)	Option 2 & 3 See tables 1 & 2				Steady state
vs. supply voltage variation (pushing)			± 10	ppb	V _S ±5%
vs. load change (pulling)			± 10	ppb	Load ±10%
Long term (aging) per day, (after 30 days operation) (Note 2)			± 10 ± 2	ppb ppb	AT-Cut SC-Cut
long term (aging) 1 st year (after 30 days operation) (Note 2)		± 300 ± 50	± 500 ± 200	ppb ppb	AT-Cut SC-Cut
Frequency adjustment range					
Electronic Frequency Control (EFC)	±2 ± 0.8		±5	ppm ppm	AT-Cut SC-Cut
EFC voltage V _C	0	V _{REF} /2	V _{REF}	V	
EFC slope (Δf / ΔV _C)	positive				
EFC input impedance	100			kΩ	
RF output					
Signal waveform	HCMOS				
Load	15			pF	±10%
Rise & decay time			5	ns	@10% to 90% V _S
Symmetry (duty cycle)	40		60	%	@ V _S /2
Warm-up time @ +25°C		3	5	min	Δf _{final} /f ₀ < ±0.1 ppm
Phase Noise					
Consult factory					
Reference voltage V _{REF} output (Note 3)		3.0 4.0 5.0		V V V	Option 1 = "33" Option 1 = "50" Option 1 = "12"
Supply voltage V _S	3.15 4.75 11.4	3.3 5.0 12.0	3.45 5.25 12.6	V V V	Option I = "33" Option I = "50" Option I = "12"
Current consumption (steady state) @ +25°C (Note 4)			300 200 100	mA mA mA	Option I = "33" Option I = "50" Option I = "12"
Current consumption (warm-up) (Note 4)			800 600 300	mA mA mA	Option I = "33" Option I = "50" Option I = "12"
Enclosure (see drawing) (LxWxH) Note 5	25.6x22.2x12 max.			mm	IEC 60679-3 CO 28
Weight			15	gram	
Packing	Tape & reel				IEC 60286-3

Notes:

1. Terminology and test conditions are according to IEC standard IEC60679-1 and MIL-PRF-55310, unless otherwise stated
2. Lower aging on request
3. Other reference voltages on request
4. May be higher for wide operating temperature range
5. Lower height H available on request

Data sheet

AXIOM10

High Stability SMD OCXO with HCMOS Output

Rev. 8

Date: 2014-04-18

Absolute Maximum Ratings

Parameter	min.	max.	Unit	Condition
Supply Voltage V_s	-0.5	$V_s + 10\%$	V	V_s to GND
Control Voltage V_c	-0.5	15	V	V_c to GND
Storage Temperature	-55	+125	°C	

Frequency stability vs. temperature

Option 2	Stability	Lower Temperature		Upper Temperature	
	[ppb]	Option 3	T [°C]	Option 3	T [°C]
05	±5	0	0	A	+50
10	±10	1	-10	B	+60
25	±25	2	-20	C	+70
50	±50	3	-30	D	+75
100	±100	4	-40	E	+80
200	±200	5	-55	F	+85

Table 1

Table 2

Standard: "1B" = -10 to +60°C

Temperature Range [°C]	Frequency stability [Option 2]					
	05	10	25	50	100	200
0 ~ +50	SC	SC	SC	AT	AT	AT
-10 ~ +60	SC	SC	SC	AT	AT	AT
-20 ~ +70	SC	SC	SC	SC	AT	AT
-30 ~ +70	O	SC	SC	SC	SC	AT
-40 ~ +75	O	O	SC	SC	SC	SC
-40 ~ +85	O	O	SC	SC	SC	SC
-55 ~ +85	-	O	O	SC	SC	SC

Table 3 "Availability" AT, SC = AT-Cut, SC-Cut available, O = available on request, - = not available

Environmental conditions

Test	IEC 60068 Part ...	IEC 60679-1 clause ...	MIL-STD-202G Method	MIL-STD-810F Method	MIL-PRF-55310D Clause	Test conditions (IEC)
Sealing tests (if applicable)	2-17	5.6.2	112E		3.6.1.2	Gross leak: Test Qc, Fine leak: Test Qk
Solderability	2-20	5.6.3	208H		3.6.52	Test Ta Method 1
Resistance to soldering heat	2-58		210F		3.6.48	Test Td ₁ Method 2 Test Td ₂ Method 2
Shock*	2-27	5.6.8	213B	516.4	3.6.40	Test Ea, 3 x per axes 100g, 6 ms half-sine pulse
Vibration, sinusoidal*	2-6	5.6.7.1	201A 204D	516.4-4	3.6.38.1 3.6.38.2	Test Fc, 30 min per axes, 10 Hz - 55 Hz 0,75mm; 55 Hz - 2 kHz, 10g
Vibration, random*	2-64	5.6.7.3	214A	514.5	3.6.38.3 3.6.38.4	Test Fdb
Endurance tests			108A			
- ageing		5.7.1			4.8.35	30 days @ 85°C, OCXO @25°C
- extended aging		5.7.2				1000h, 2000h, 8000h @85°C

Data sheet

AXIOM10

High Stability SMD OCXO with HCMOS Output

Enclosure drawing:

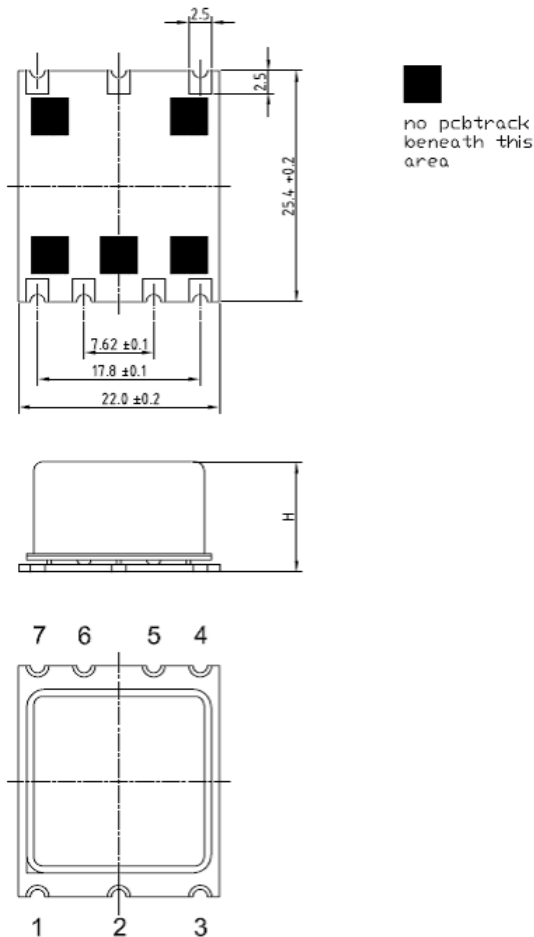

Pin connections

Pin #	Symbol	Function
1	V _C	Control Voltage (EFC)
2	VREF	Reference Voltage
3	V _S	Supply Voltage
4	RF OUT	RF Output
5	N.C.	No Connection
6	N.C.	No Connection
7	GND	Ground

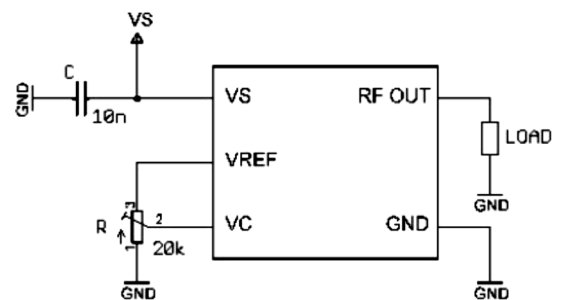

Ordering Code

Model	Option 1 [Supply Voltage]	Option 2 [Stability]	Option 3 [Temperature range]	Revision	Frequency [MHz]
AXIOM10	12, 33, 50	Table 1	Table 2	Rev.8	10.000

Example: AXIOM10-12-10-1B_Rev.8-10.000MHz

Handling and Testing:

Parameter	Procedure		Condition
Electrostatic discharge (ESD)			
THD devices	IEC60749-26	HBM	2000V
SMD devices	IEC607749-27	MM	200V
Washable	Yes		
RoHS-Compliant	Yes		